

ECR's **Alook**TM
PANEL FITMENT SYSTEM

Installation Instructions



Established in 1987

Glossary

Canopy:

The roof of the cab.

The top structural component of the shell.

The canopy houses the emergency hatch.

The canopy may have various electrical and mechanical components attached to its surfaces, both interior and exterior.

Non-Access Walls:

Any elevator cab wall which does not have an entrance.

“Panel Edge”:

A decorative component of the A-Look™ Horizontal Panel System. The Panel edge is an aluminum extruded angle used to cover the outer edges of the horizontal panels.

“Panel Interlock” (patented):

A structural and decorative component of the A-Look™ Horizontal Panel System. The “panel interlock” is an aluminum extrusion which allows one panel to be joined to another as well as to be fastened to the cab wall. This extrusion also provides a decorative accent line at the panel junction.

Return Panel:

The wall of the cab adjacent to the entrance.

The return panel may contain the control panel, phone box and/or service panel.

The car door will slide behind the return panel.

Reveals:

Area of the elevator cab walls not covered by the panels. This area is usually covered with stainless steel or plastic laminate.

Strike Post:

Part of the door frame on which the door closes.

1. Before You Begin the Installation

1.0 Installing instructions

Your installer should view the installation video (available on-line at www.alookcabs.com) as well as review the following instructions.

1.1 Unpacking

When your new A-Look™ cab arrives, transport it near to the cab you will be renovating and organize the crates so that they will be easily accessible.

The crate's contents are itemized on its surface.

Carefully uncrate the cab package, making sure that none of the components are damaged.

Check the colours, features, and dimensions of the components against your order before you begin removing the existing elevator interior.

Note the labelling on the components. The labels indicate the order in which the components will be installed and will help you identify the correct component called for in the instructions (Diagram 1).

If you have any questions at this point, contact ECR before going ahead with any part of the installation.

Diagram 1: Component labeling

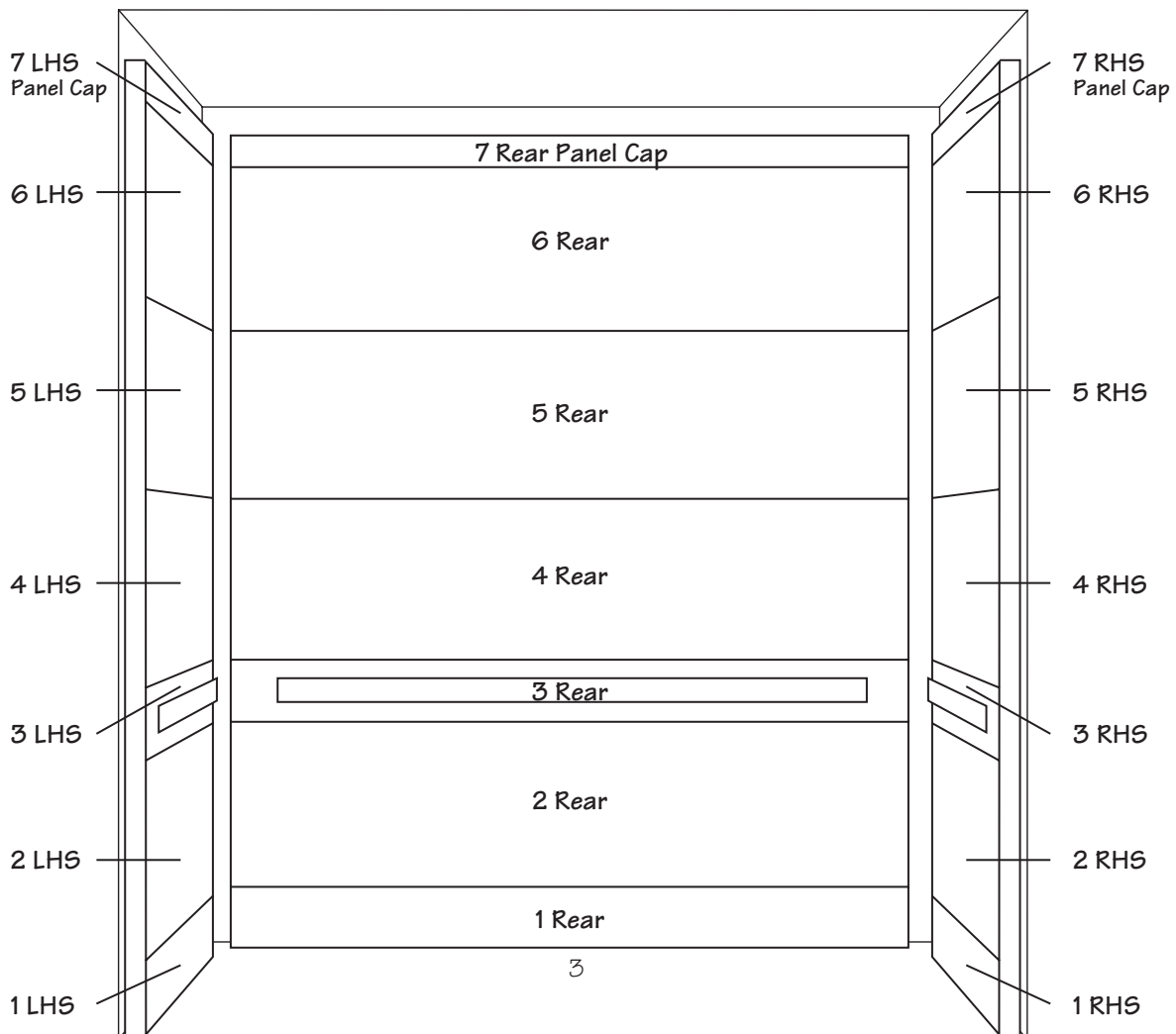

1.2 Components of the A-Look™ Panel System

The Horizontal A-Look™ Panel System is made up of the following parts:

Aluminum "J" shaped starter strip

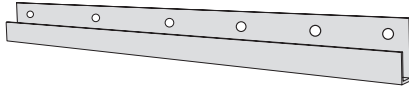

A-Look™ Panel interlock

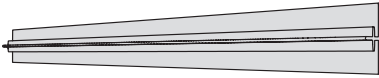

Kickplate panel complete with panel interlock

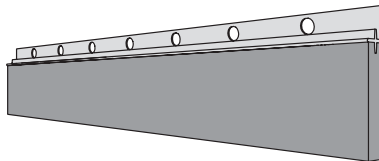

Handrail panel complete with panel interlock and separate handrail.



Several panels complete with panel interlock, covered in plastic laminate, mirror, or decorative metal

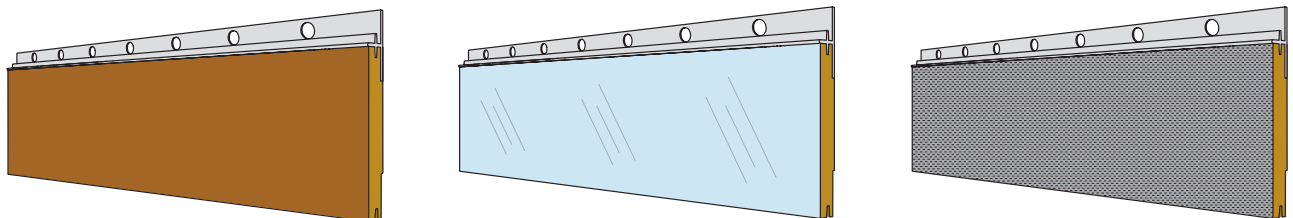

Panel cap, normally covered with SS#4



Vertical panel edge of extruded aluminum.



Z-Bar to fasten the Panel Cap to the wall. (illustration to come)

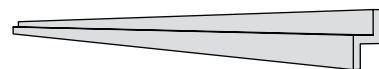

Pieces are pre-sized to fit their corresponding wall.

All parts will be marked as illustrated in the labeling diagram (Diagram 1)

1.3 Preparing your cab for installation

Before installing your new cab interior you must remove all existing finishes and prepare the cab shell.

If the flooring is not being replaced, begin by placing a protective covering over the floor. This will prevent damage to the floor throughout the installation.

Remove all existing finishes, stripping the cab down to the bare shell.

Before continuing, clean any debris and oil from the cab shell.

If the flooring is being replaced, this task should be completed prior to the application of the new wall finishes.

You now have the option to:

A) paint the top 6" of all non-access walls with matte black paint (paint is not included)

OR

B) Wait until the vertical reveals are installed (Section 2.2). Once these corner reveals are installed you may in-fill the area between these vertical pieces. Strips of stainless have been provided to cover the area and are to be installed horizontally along the wall at the junction of the canopy. These horizontal reveals will have to be cut to suit.

If you are installing a new suspended ceiling, remove the existing ceiling and hardware.

If you have chosen our Venture model suspended ceiling (Diagram 2), you will be required to paint the perimeter of the canopy 4" in from all sides with matte black latex paint. (Paint is not included)

The remainder of the canopy will not be visible once the Venture model suspended ceiling is installed.

If you have chosen our Advantage model suspended ceiling (Diagram 3) the canopy remains somewhat visible through the eggcrate panels. Patching and painting the canopy ensures a more finished appearance. Typically, a white semigloss latex paint is used for this purpose. (Paint is not included)

Diagram 2: Venture model suspended ceiling

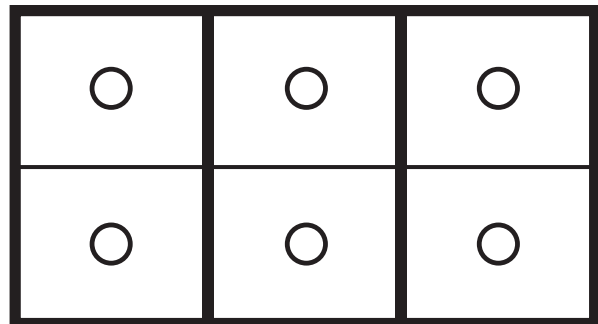
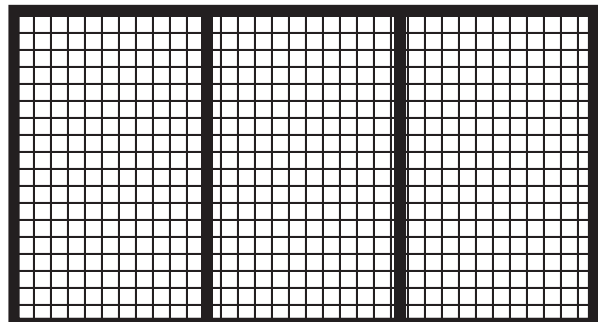

Diagram 3: Advantage model suspended ceiling



1.4 The tools you will need for the installation

Pencil
High Quality Measuring Tape
Drill
Hack Saw with 12D/32T Blade
Jigsaw
Self-Centering Punch
Framing Square
7/16" Wrench
Ladder
2" or 3" Paint Brush for Latex Paint
Caulking Gun
Rivet Gun

2. Installing the Reveals

2.1 Introduction

Locate stainless steel reveals provided. These reveals are either flat or formed into an inside corner angle and include two strips of two-sided tape to fasten them to the walls.

Check the fit of the reveals before installing. They can be up to 1/4" short of the canopy without affecting the aesthetic quality of the finished product.

Cut any reveals that are too long using either a hacksaw or a jigsaw equipped with a 32 TPI blade.

Each reveal has two strips of double sided tape on the back to fasten them to the walls. Do not remove the protective film from the tape until you are ready to install the reveal.

Flat reveals are to be installed at the front edge of the sidewalls (next to return panels or against strike post). Where the header of the car is proud of the return below it, the front reveal must be either notched or installed in two pieces. (Diagram 4) Modification can be done using a hacksaw or jig saw.

Diagram 4: Proud header

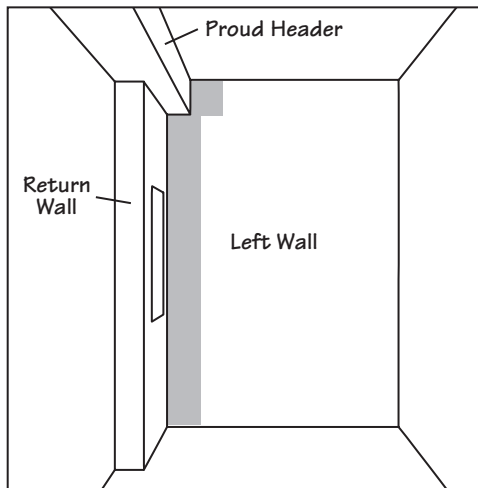

2.2 Install reveals in the following manner:

Side Reveals: Dry fit the reveals and modify if necessary. Peel film from the two-sided tape on flat reveals and, starting at the bottom, press to sidewall ensuring a tight fit against front of cab (Diagram 5). When a front reveal is split at the header (Diagram 6), start pressing the reveal to the wall at this seam and work away from the seam.

Diagram 5: Side reveal installation

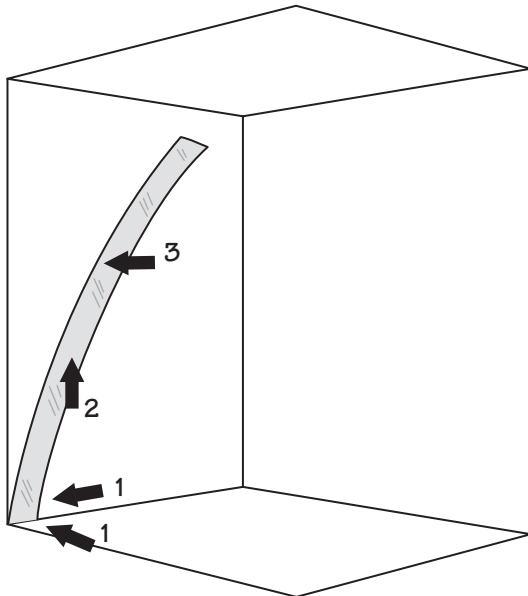
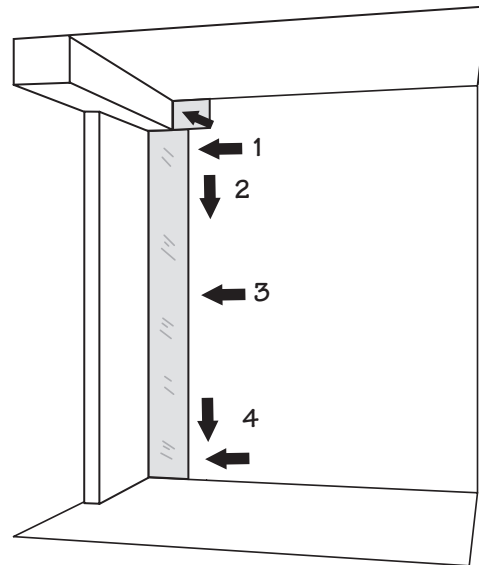
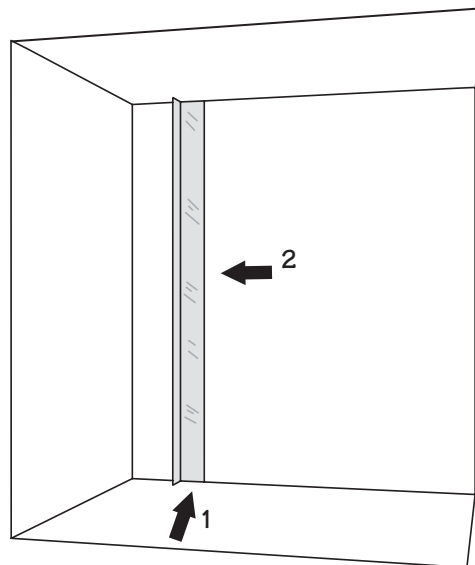

Diagram 6: Side reveal installation (split reveal)



Corner Reveals: Dry fit the reveals and modify if necessary. Peel film from the two sided tape on one side of the inside corner angle. Place non-taped outside face of corner reveal against the rear wall and, keeping this face tight to the wall, slide the reveal into position against the side wall, engaging the tape. Apply pressure to ensure the angle adheres to the sidewall (Diagram 7).

Diagram 7: Corner reveal installation



3. The A-Look™ Horizontal Panel System

3.1 Installing the A-Look™ Panel System

After identifying all the parts, begin installation by:

Measuring the width of each wall and determining the center point. Mark a line vertically at this point (Diagram 8).

Diagram 8: Marking the center line

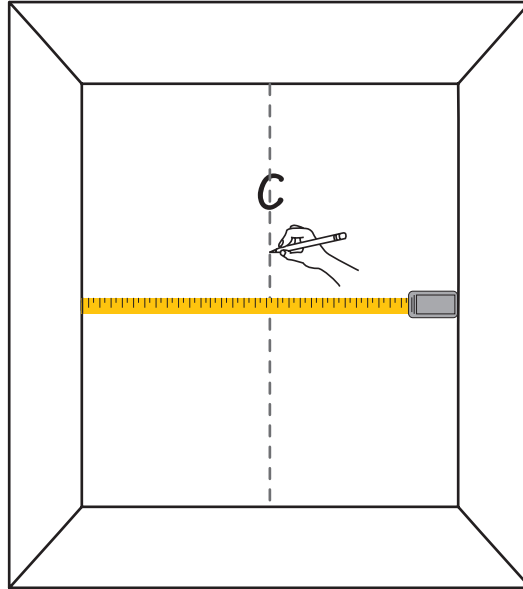

Determine the center of the aluminum “J” shaped starter strip for the back wall and mark it. Align this mark with the center mark on the back wall and fasten the starter strip to wall.

Install rear kickplate panel (#1 series) by inserting the panel on the starter strip so that the grooved edge of panel without the panel interlock fits over the front lip of starter strip. (Diagram 9)

Fasten kickplate panel to wall using screws through counter sunk holes provided in panel interlock. At this point, use only the two holes closest to the center of the “panel interlock”.

Check to see that the kickplate is set square to the adjacent walls using a framing square. This will ensure that the subsequent panels will line up with the kickplate and will retain the same reveal dimension in each corner as they are installed.

Repeat these steps for the side wall kickplates.

NOTE: At this point it is crucial to check that kickplates are square to adjacent walls and are at the same height on all three non-access walls. Although a difference in height may not be noticeable at this point, it will become quite evident when the height of the panels approaches eye level. Make adjustments to the height of the kickplates to correct any problems that may exist.

Diagram 9: Starter strip

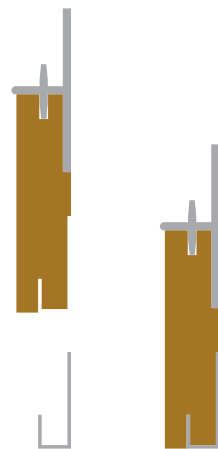

Before completely securing the panel interlock to the walls, insert the panel edge so that the rounded edge (1/8" thick) faces into the cab and the thinner portion of panel edge is flat against the wall. Hold the panel edge tight against the end of the kickplate and screw or rivet the panel edge to the wall (Diagram 10). Repeat this process at the other end of the kickplate.

Diagram 10: Panel edge installation

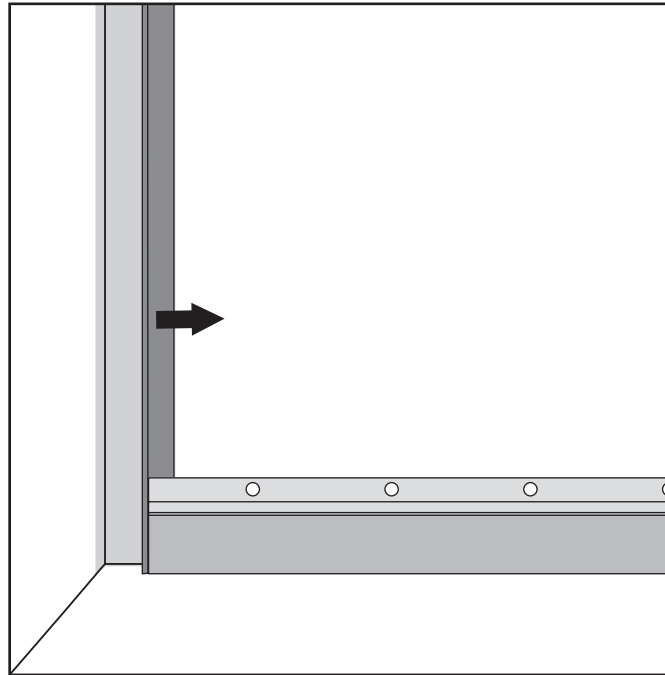

In high use cabs it can be beneficial to remove the kick plates and apply additional rivets close to the floor level through the panel edge. These additional fasteners help the panel edge to remain in place should they be subjected to impact or misuse.

With both panel edge extrusions secured in place and tight to the ends of the kickplates finish fastening the panel interlock to the wall using the holes provided.

Locate the next panel to be installed (#2 series). Check the panel interlock of previous panel for any debris and remove as necessary.

Insert panel into panel interlock of kickplate and align vertical edges with those of previous panel. When edges align, fasten panel to wall using center screw holes in panel interlock. As with kickplate, place panel edge tight to the ends of the panels and fasten to wall above the panel interlock. Finish fastening panel interlock through the holes provided. (Diagram 11)

Diagram 11: Installing a panel

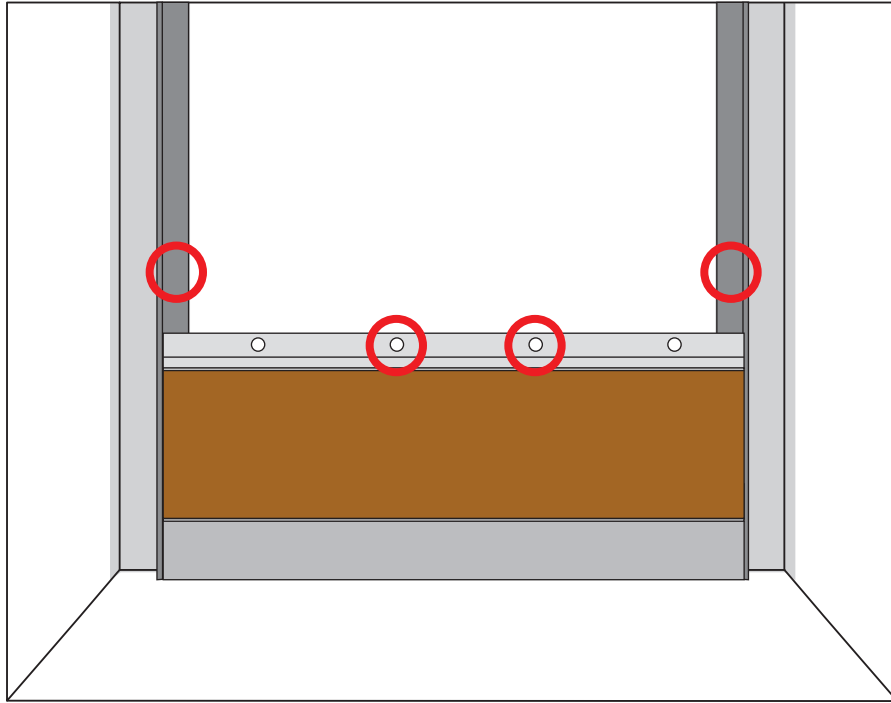

The next panel in the installation is the handrail panel (# 3 series). The handrail is mounted through this panel. The handrail panel and handrail are provided disassembled and require a specific mounting procedure.

3.1.1 Installing the handrail panel and handrail (Diagram 12)

Temporarily install the handrail panel (H.P.). Once the H.P. is in place transfer the hole locations from the H.P. to the cab shell.

Remove the H.P. and drill $\frac{1}{2}$ " holes in to the cab shell as marked on the previous step.

Re-install the H.P. The holes in the panel should correspond with the holes in the shell.

Insert and secure the provided togglers through the handrail panel and the shell. You are now ready to fasten the handrail to the panel.

Place the flared end of a stainless steel standoff against the handrail panel, centered on the toggler.

Fasten this to the wall and H.P. with the $\frac{1}{4}$ " - 20 bolts provided.

Inserts are attached to the handrail. Slide the inserts into the standoff.

Secure the handrail to the standoff using the set screws provided.

Repeat this process for all handrail panels, ensuring that you have installed a standoff for each of the pre-drilled holes in the handrail panels.

Diagram 12: Handrail panel and handrail mounting

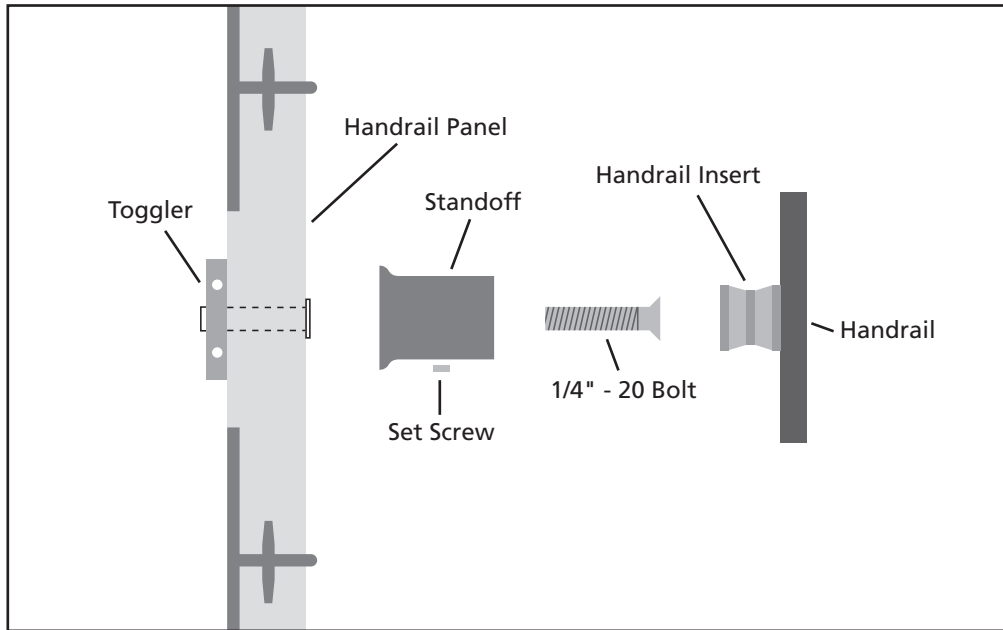

3.1.2 Finishing the A-Look panel installation

For the Ashbury model which includes laminate panels for the back wall of cab above the handrail (#4 series through #6 series) install them now using methods described above.

If mirrors were chosen for the back wall of the cab above the handrail (Providence model), locate the first mirror (#4 Rear series). Install this panel carefully into the previous panel interlock.

NOTE: mirror edges are vulnerable once protective packing is removed. Handle With Care.

Fasten the panel edge and the panel interlock to the wall using holes provided.

Install remaining panels to back wall (# 5 series and # 6 series) using the same methods.

The final piece to be installed on each wall is the panel cap. This piece is typically faced with stainless steel and is grooved along the top and bottom edges.

The bottom groove will mate with the panel interlock while the top groove will accept a Z bar. Once screwed to the cab shell the Z bar firmly locks the panel cap into position. (see diagram 13)

Having completed the back wall, locate the next panel needed for one of the sidewalls (#2 LHS series). Install as per instructions for the back wall, working your way up the wall (#3 series through #6) and finishing off with the panel cap. Repeat process for the other sidewall.

Diagram 13: Top cap and Z-Bar

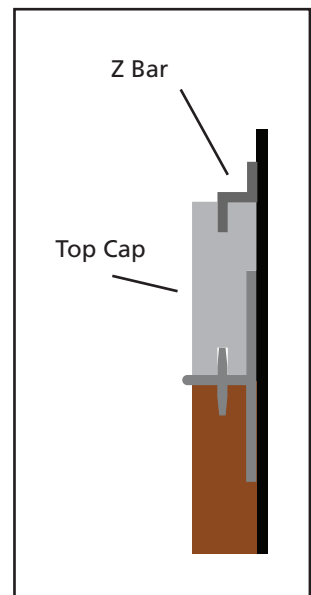

4.0 Ceiling Installation

4.1 Preparing for installation

Prepare ceiling surface to accept new ceiling finishes (see section on cab preparation).

The "T" frame will be disassembled for shipping purposes. Assembly instructions for your specific ceiling will be provided with the package.

Assemble the false ceiling frame and mounting brackets.

Center the assembly on the canopy and mark the holes through the mounting brackets.

Before drilling in the canopy, check the top of the car for any obstructions (i.e. ducts, cable, conduit etc.). Move any brackets that may be obstructed. Do this by removing the bracket from the frame and re-drilling the frame in a new, unobstructed location.

Drill ½" diameter mounting holes in the canopy. This will allow for adequate adjustment later.

For stability, a minimum of two brackets should be oriented from front to back and a minimum of two brackets should be run side to side. On larger ceilings, more brackets may be used to shorten the span between supports. Typical ceilings require only 4 support brackets.

Diagram 14: Assembled ceiling frame

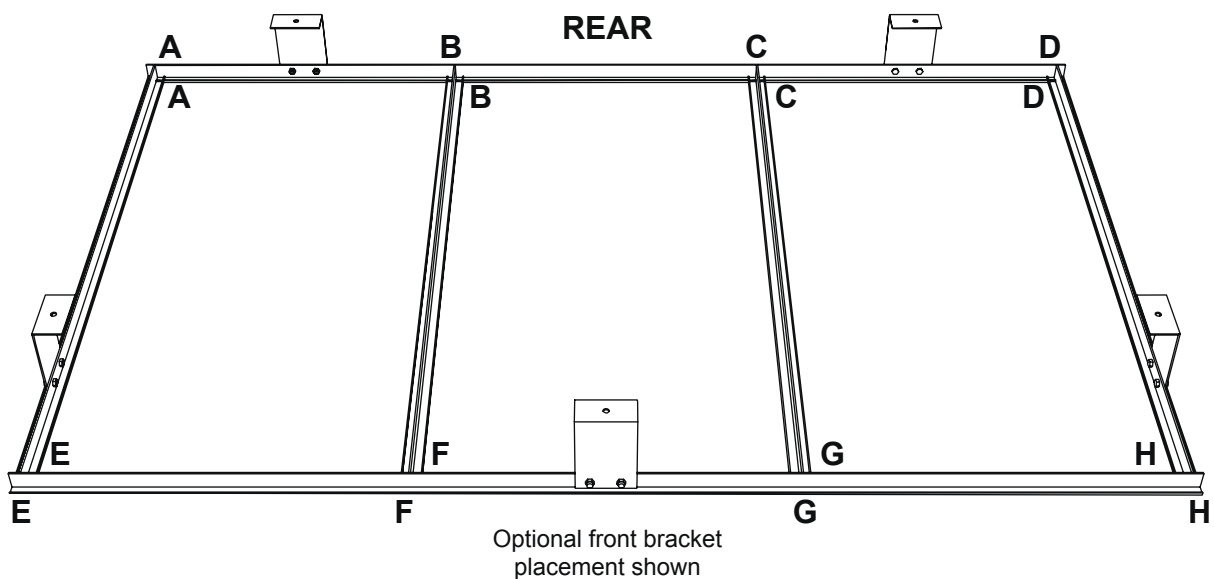

4.2 Installing the ceiling frame

Raise the assembled ceiling frame and fasten it to the canopy using the 2" x ¼ - 20 bolts, washers, lock washers and nuts provided.

Diagram 15: Assembled ceiling frame mounted to cab ceiling

Optional front bracket
placement shown

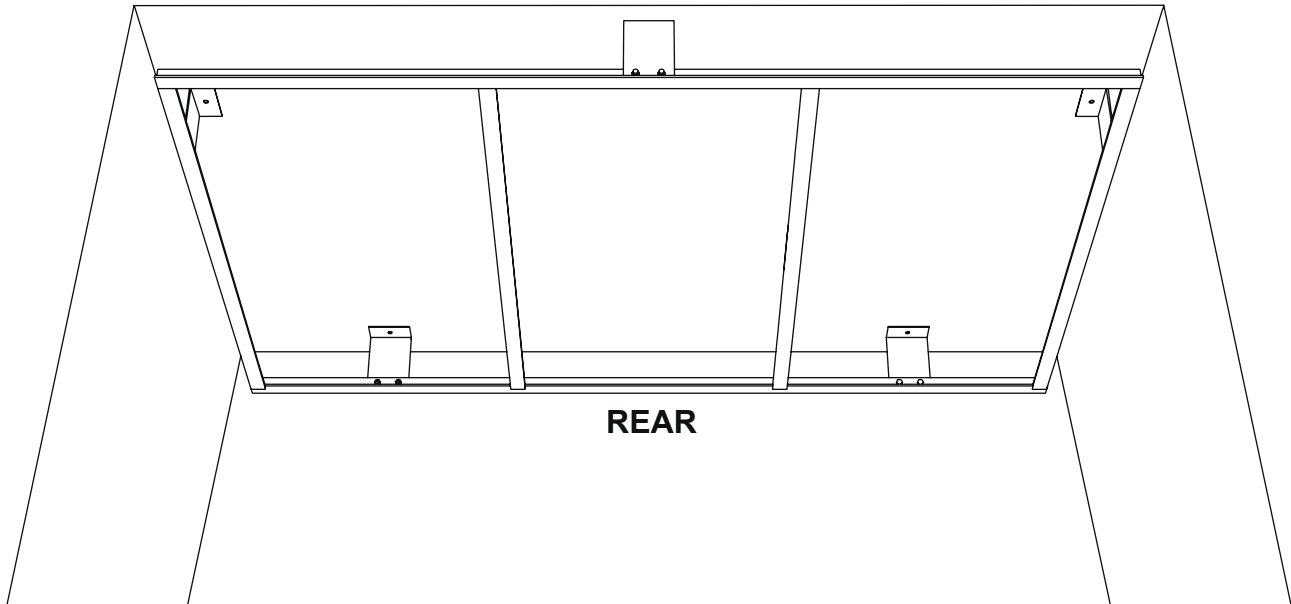

Make any adjustments necessary to center the ceiling frame on the canopy prior to tightening the bolts. Locktite™ can be applied to the nut/bolt assembly for added security. Trim any excess bolt protruding from the canopy to avoid trip hazards.

4.3 Installing the Venture model ceiling

For the Venture model suspended ceiling, stainless steel pans containing low voltage pot lights are provided, a receptacle will be required to power the transformers. Locate the receptacle inside the limits of the ceiling frame but not directly above the location of a light fixture or on the hatch. Mount the electrical box and transformers (provided) to the canopy. It is most convenient to have the receptacle facing down. Again ensure there are no obstructions above the canopy before mounting the electrical box and transformers.

The low voltage pot lights included with the ceiling are equipped with a 60 watt transformer and wiring harness to power three 20 watt lamps. Do not exceed the 20 watt lamp requirement or the transformer will shut down.

Place ceiling pans as labeled. Install the front ceiling pans first. The pan with handles and safety chain is to be installed below the escape hatch. Install ceiling pans, plugging each fixture into its transformer via the wiring harness. (see diagram 16 on the following page)

Remove any protective plastic remaining.

Please note that retainer clips are supplied with the Venture model ceiling. These clips provide added security while holding the S.S. pans firmly in place. It is important to ensure these clips are in place during full speed buffer testing. (see diagram 18).

**Diagram 16: Assembled Venture ceiling
Handles and safety chain on hatch panel**

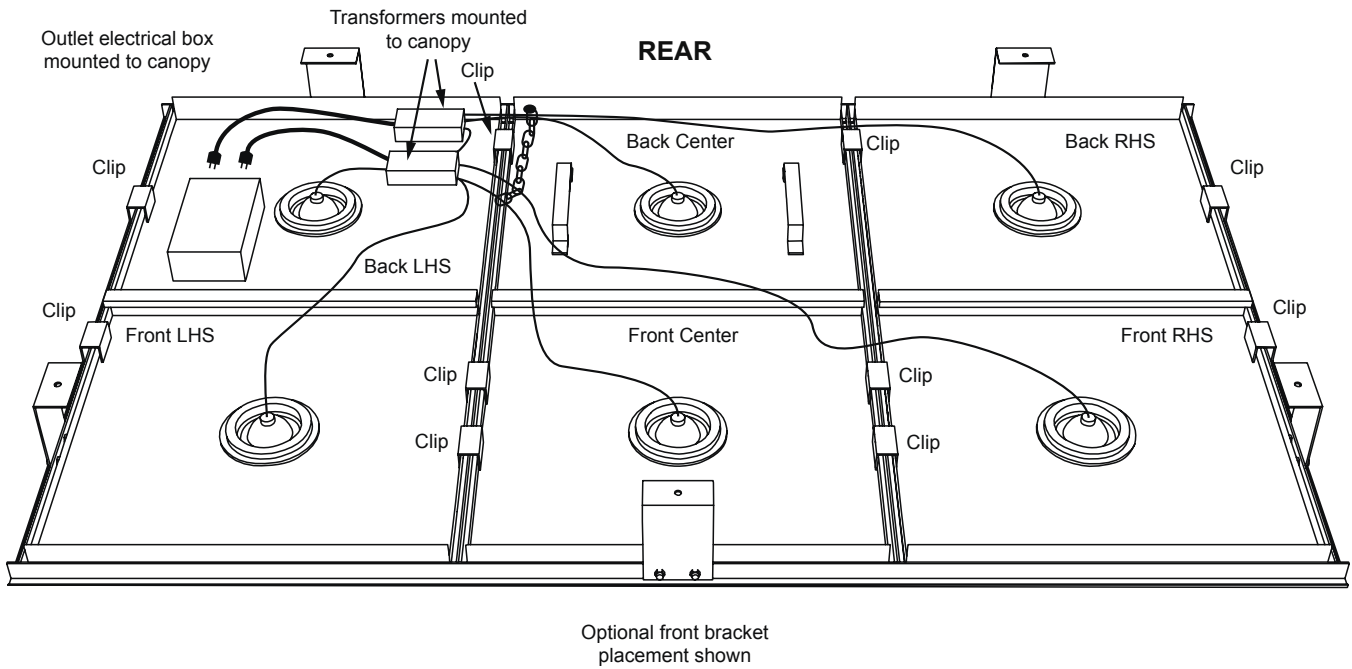

Diagram 17: Side section of ceiling panels

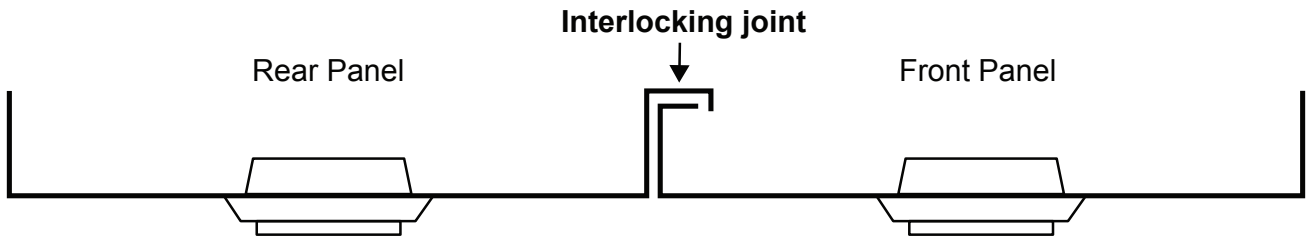
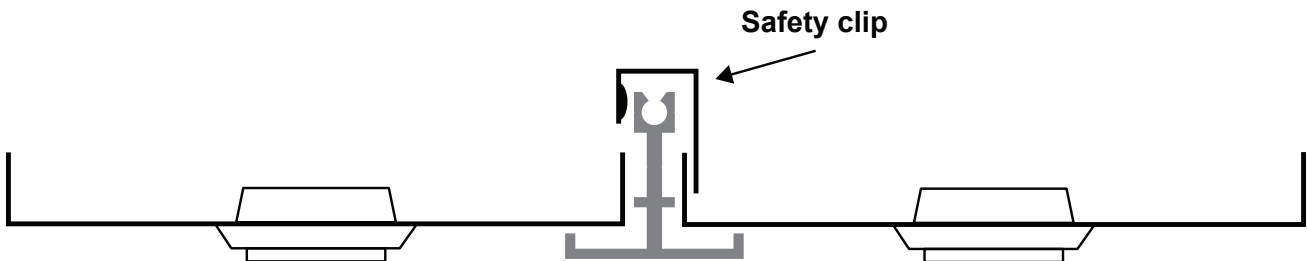

Diagram 18: Side section of ceiling panels showing installed safety clip



4.4 Installing the Advantage model ceiling

For the Advantage model suspended ceiling, install pre-cut aluminum eggcrate into the openings in the ceiling frame. These pieces are cut to fit snugly in frame and may need to be pulled down to sit flat on the frame.

Note: Fluorescent fixtures are not supplied with this model unless requested.

Diagram 19: Assembled Advantage ceiling (lights shown for illustration purposes only)

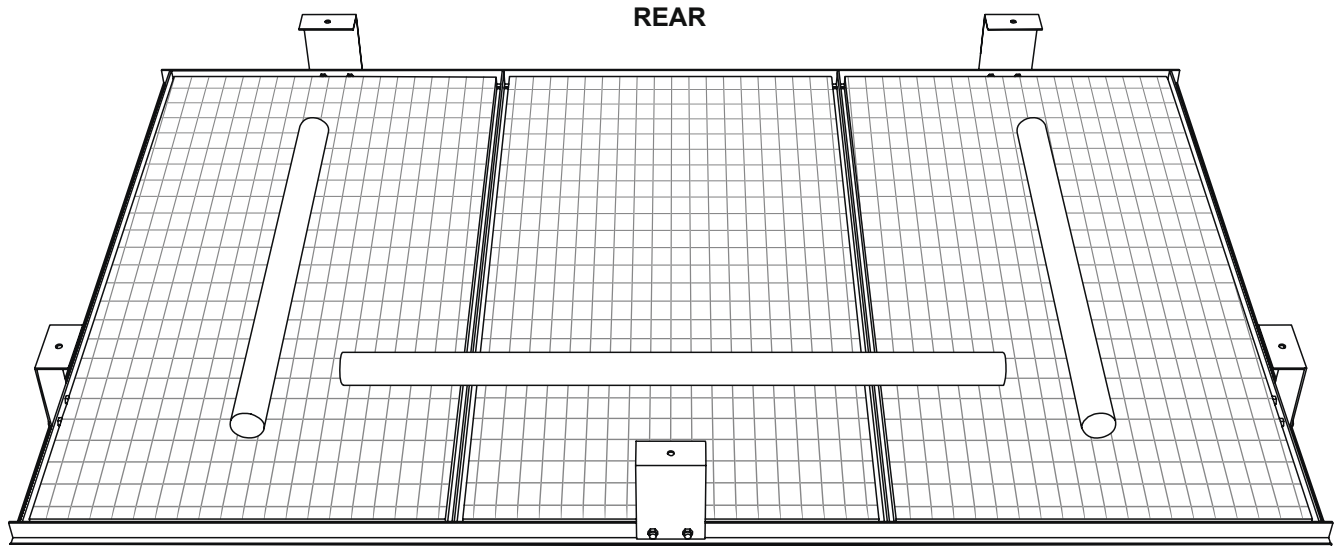

Optional front bracket
placement shown